

IK-4KH & IK-4KE

**4K ULTRA HD Mini Camera
3CMOS Microprism
3G/HD-SDI x 4**

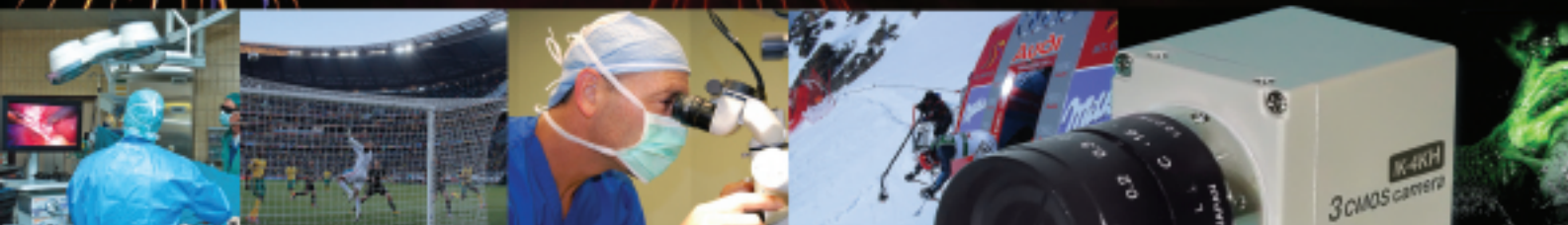

Features

- Ultra-compact camera head
- 3CMOS, 1/2.9" progressive sensors
- 3840 x 2160p Resolution
- Switchable 4K, 1080p/1080i
- Up to 1600 TVL Resolution
- 3G-SDI/HD-SDI x4
- C-mount lens
- Remote Control via RS 232

Toshiba is proud to introduce the brand new 3-CMOS, 4K Ultra HD 3840 x 2160p, 50/59.94 Hz camera system, designed to provide stunningly sharp detail and incredibly rich colour in 4K resolution.

This new generation remote head power house, will suit all vision applications where colour fidelity and resolution are critical, including broadcasting, clinical and defense imaging.



TOSHIBA
Leading Innovation >>>

IK-4K

Camera Head Specifications IK-4KH

Image Sensor	1/2.9 inch 3-CMOS
Output Resolution	Horizontal: 3840 Vertical: 2160
Resolution: H : V	1600 TVL [4K]; 1000 TVL [1080p/1080i] 1600 TVL [4K]; 1000 TVL [1080p/1080i]
Minimum Illumination	16.2 lx (50 Hz settings) at F2.2, 24dB 19.5 lx (59.94Hz settings) at F2.2, 24 dB
S/N Ratio	58 dB standard (AGC: OFF; GAMMA OFF; Martix OFF; Lens closed)
Operating Temperature	0 to 40 C (32 to 104 F)
Operating Humidity	Less than 90% (non condensing)
Weight	Approx. 70 g.
Dimensions	32.6 mm (W) x 38.6 mm (H) x 41 mm (D)

Camera Head Exterior Dimensions

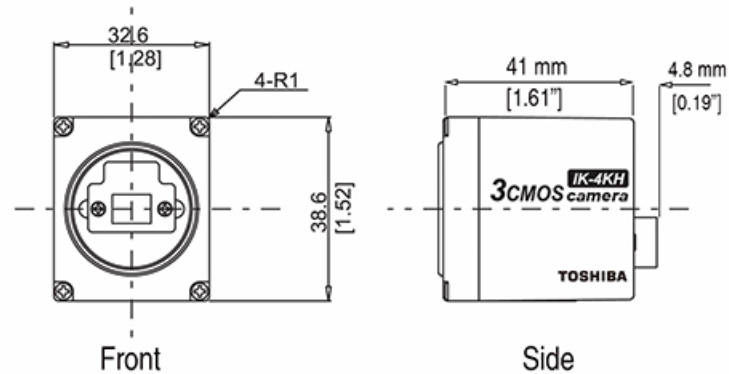

IK-4KE Controller Specifications

Power Supply	DC 12V 10%
Power Consumption	13.8 W (including camera head)
Scanning System	Progressive/Interlace
Scan Frequency	H: 56.250kHz, V: 50 Hz (4K / 1080p Mode) H: 67.433kHz V: 59.94Hz (4K / 1080p Mode) H: 28.125kHz, V: 50Hz (1080i Mode) H: 33.716kHz, V: 59.94Hz (1080i Mode)
Operating Temperature	0 to 40 C (32 to 104 F)
Operating Humidity	Less than 90% (non condensing)
Weight	800 g. (1.76 lbs)
Dimensions	110mm (W) x 40 mm (H) x 196 mm (D)
Scene Files	A, B, C, D, E
White Balance	AWB (Automatic White Balance); MANUAL
Freeze	AUTO (Automatic gain control); MANUAL (Manual); OFF (0 dB)
Output Signal	[4K Mode] 3G-SDI 4Division [1080 p/i Mode] 3G-SDI x4 / HD-SDI x4
Electronic Shutter	AUTO / MANU / OFF - 1/10000s

Controller Front and Back Panels

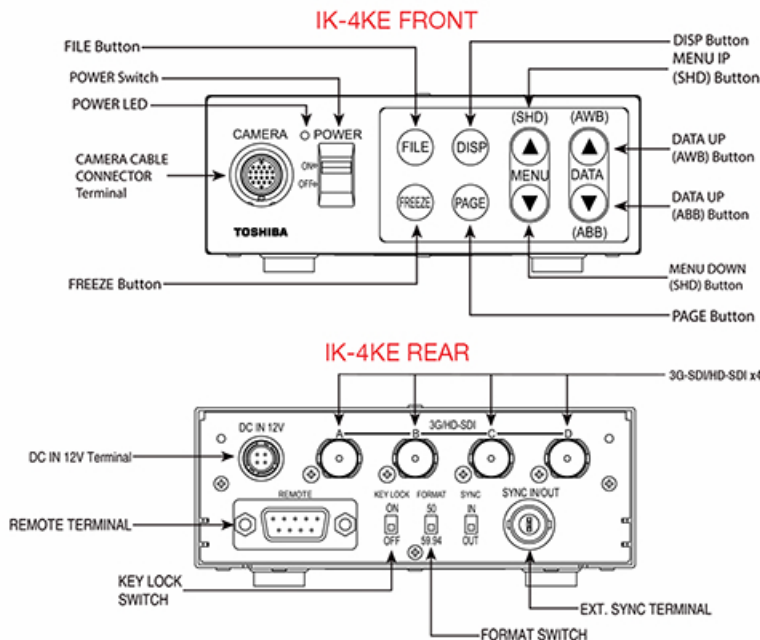

CAMERA HEAD

IK-4KH

CAMERA CONTROL UNIT

IK-4KE

CAMERA CABLE

Model	Length
EXC-3HD03	3 m
EXC-3HD06	6 m
EXC-3HD10	10 m
EXC-3HD15	15 m

TOSHIBA
Leading Innovation >>>

Toshiba Europe GmbH

www.toshiba.ch/ics

professional@toshiba.ch